

# Diethylene glycol/NaBr catalyzed CO<sub>2</sub> insertion into terminal epoxides: from batch to continuous flow

Davide Rigo, Roberto Calmanti, Alvisè Perosa, Maurizio Selva\* and Giulia Fiorani\*

Department of Molecular Sciences and Nanosystems,  
Ca' Foscari University of Venezia  
Via Torino 155, 30172, Venezia Mestre (Italy)  
[selva@unive.it](mailto:selva@unive.it); [giulia.fiorani@unive.it](mailto:giulia.fiorani@unive.it)

Supporting information for this article is given via a link at the end of the document.

**Abstract:** CO<sub>2</sub> insertion reactions on terminal epoxides (styrene oxide, 1,2-epoxyhexane and butyl glycidyl ether) were performed in a binary homogeneous mixture comprising NaBr as the nucleophilic catalyst and diethylene glycol (DEG) as both solvent and catalyst activator (cation coordinating agent). The reaction protocol was initially studied under batch conditions either in autoclaves and glass reactors: quantitative formation of the cyclic organic carbonate products (COCs) were achieved at T = 100 °C and  $p^0(\text{CO}_2) = 1 - 40$  bar. The process was then transferred to continuous-flow (CF) mode. The effects of the reaction parameters (T,  $p(\text{CO}_2)$ , catalyst loading, and flow rates) were studied using microfluidic reactors of capacities variable from  $7.85 \cdot 10^{-2}$  to  $0.157 \text{ cm}^3$ . Albeit the CF reaction took place at T = 220 °C and 120 bar, CF improved the productivity and allowed catalyst recycle through a semi-continuous extraction procedure. For the model case of 1,2-epoxyhexane, the (non-optimised) rate of formation of the corresponding carbonate, 4-butyl-1,3-dioxolan-2-one, was increased up to  $27.6 \text{ mmol h}^{-1} \text{ equiv}^{-1}$ , a value 2.5 higher than in the batch mode. Moreover, the NaBr/DEG mixture was reusable without loss of performance for at least 4 subsequent CF-tests.

## Introduction

In recent years, the range of synthetically relevant applications of carbon dioxide (CO<sub>2</sub>) has extended tremendously, shifting from a niche research area to an established stimulating, interdisciplinary research topic.<sup>[1,2]</sup> The most notable examples of non-reductive transformations employing CO<sub>2</sub> as C<sup>1</sup> electrophilic synthon include carboxylation and CO<sub>2</sub> insertion reactions,<sup>[3]</sup> which are highly desirable from the green chemistry perspective as they valorise a renewable resource through atom economical chemical processes. Among them, a cornerstone is represented by the synthesis of cyclic organic carbonates (COCs) via CO<sub>2</sub> insertion in epoxide rings (Scheme 1).

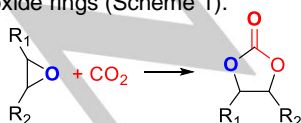

**Scheme 1.** Formation of 5-membered COCs via CO<sub>2</sub> insertion in epoxide rings in presence of a suitable catalytic system.

Although the reaction often proceeds with good to excellent yields, it exemplifies some of the typical issues/challenges associated to

the use of CO<sub>2</sub> in synthesis. Indeed, due to the high thermodynamic stability and low kinetic reactivity of CO<sub>2</sub>, the process requires: i) high-energy co-reactants (epoxides) and active (and often tailor-made) catalytic systems embedding Lewis/Brønsted acid and nucleophilic moieties; ii) relatively high temperatures and/or CO<sub>2</sub> pressures which imply the design of engineering solutions through (pressurized) reaction vessels. Figure 1 depicts the mechanism proposed for COCs synthesis from epoxides and CO<sub>2</sub> in the presence of a bi-functional catalytic system (M-Nu).<sup>[4,5]</sup>

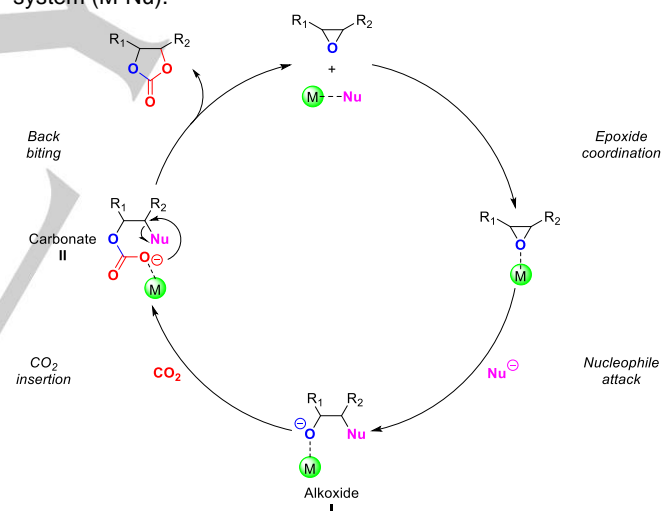

**Figure 1.** Proposed mechanism for the synthesis of 5-membered COC by reacting CO<sub>2</sub> with epoxides in the presence of a bifunctional catalytic system.

The acidic moiety (M) of the catalyst coordinates the epoxide activation; the resulting activated substrate undergoes attack by the nucleophilic component (Nu) of the catalyst, generally a halide, resulting in the formation of an alkoxide intermediate (I). Thereafter, the reaction of I and CO<sub>2</sub> forms a carbonate intermediate (II) which undergoes ring closure via a back-biting reaction. This final step releases the COC product, and concurrently restores the catalytic system. A plethora of such systems active for terminal, internal and trisubstituted epoxides have been reported so far.<sup>[6]</sup> In view of more sustainable protocols, special emphasis has been devoted to non-endangered metal catalysts<sup>[7]</sup> such as salts and complexes of Fe, Al, Co and Zn,<sup>[8-11]</sup> and, even more interesting, some of these systems have proved efficient in continuous-flow (CF) mode, i.e. under highly

reliable conditions for process optimization, intensification and upscaling.<sup>[12]</sup> One of the first CF-examples described a Co<sup>II</sup>-salen complex immobilized on MCM-41 silica gel: at T = 110 °C, p(CO<sub>2</sub>) = 125 bar and F = 10-20 mL·h<sup>-1</sup>, in the presence of tetrabutylammonium bromide (TBAB) as a co-catalyst, ethylene oxide (EO) was converted up to 86% into ethylene carbonate (EC) with > 99 % selectivity.<sup>[13]</sup> Another approach proposed a Zn-based imidazolium ionic liquid ([AeMIM][Zn<sub>2</sub>Br<sub>5</sub>]) supported on MCM-22 molecular sieves, to obtain propylene carbonate (PC) from propylene oxide (PO). A steady PC yield of 62% was reported after > 50 h of time-on-stream, at T = 130 °C, p(CO<sub>2</sub>) = 20 bar, LHSV = 0.75 h<sup>-1</sup> employing a molar ratio CO<sub>2</sub>/PO = 3.<sup>[14]</sup> An Al<sup>III</sup>-salen complex modified with (diethylbenzyl)ammonium bromide tethers and immobilized on amorphous silica proved effective for the first continuous-flow synthesis of EC designed for using waste CO<sub>2</sub> originated for example, in the exhaust stream of a fossil fuel power station. At T = 150 °C, when a binary mixture of N<sub>2</sub> and CO<sub>2</sub> at a total flow rate of 4.7 mL min<sup>-1</sup>, was allowed to pass through (pressurized) liquid EO, 57 % of the carbon dioxide was converted into ethylene carbonate, with a TOF of 7.6 h<sup>-1</sup>.<sup>[15]</sup> More recently, CF CO<sub>2</sub> insertion was performed in a tube-in-tube gas-liquid reactor comprised of a CO<sub>2</sub> permeable inner coil continuously fed by styrene oxide (SO) and a mixture of tetrabutylammonium bromide and zinc bromide (TBAB/ZnBr<sub>2</sub> as a homogeneous catalyst), surrounded by an external jacket pressurized with CO<sub>2</sub>: this configuration allowed a quantitative SO conversion under relatively mild conditions (T = 120 °C, p(CO<sub>2</sub>) = 6 bar).<sup>[16]</sup> Heterogeneous catalytic systems based on d-block metal catalysts were also employed for CO<sub>2</sub> insertion in CF conditions. For instance, NbCl<sub>5</sub> and the ionic liquid 1-hydroxypropyl-3-n-butylimidazolium chloride, supported on protonated carboxymethylcellulose (HBimCl-NbCl<sub>5</sub>/HCMC), were tested as catalysts for CO<sub>2</sub> insertion in a library of epoxides at T = 130 °C and p(CO<sub>2</sub>) = 15 bar (6 examples, yields=68 - 99%).<sup>[17]</sup> More recently, a metal-organic framework modified with Sc [MOF MIL-101(Sc)] was active for the conversion of PO to PC in up to 57 % yield, using chlorobenzene as a solvent at T = 100 °C and p(CO<sub>2</sub>) = 5 bar.<sup>[18]</sup> On the other hand, catalytic systems based on salts/complexes of alkali and alkaline earth metals have been less investigated for the preparation of COCs. One of the few available studies reported a Cs-P-Si fixed bed reactor which, albeit active for the transformation of propylene oxide (PO) to propylene carbonate (T = 200 °C, p(CO<sub>2</sub>) = 140 bar, PO/CO<sub>2</sub> at F = 0.2 mL·min<sup>-1</sup>, conversions up to 81%), showed extensive catalyst leaching in the reaction mixture with complete deactivation in t = 5 h.<sup>[19]</sup> Other strategies to carry out CO<sub>2</sub> insertion into terminal epoxides over alkali/alkaline earth metal-based catalysts were limited only to batch conditions. Typically, reactions were performed in homogenous conditions in the presence of co-catalysts acting as both hydrogen bond donor and cation coordinating agents,<sup>[20]</sup> e. g. glycols, crown ethers and polyethers,<sup>[21-23]</sup> which were also necessary to overcome the well-known solubility issues of metal salts in epoxides/organic solvents. For example, a system comprised of KBr embedded in polyethylene glycol 400 (PEG400) was reported for the conversion of a library of epoxides (13 examples) into the corresponding carbonates with yields > 90 % in all cases.<sup>[24]</sup> More recently, in a similar fashion, Ca<sub>2</sub> in combination with poly(ethyleneglycol) dimethyl ether (PEG DME 500) proved effective towards CO<sub>2</sub> insertion into both terminal and internal

epoxides: at T = 25-90 °C and p(CO<sub>2</sub>) of 10-50 bar, the corresponding COCs (27 examples) were obtained in variable yields from 51 to 99%. The catalytic system was then further optimized using PEG400 dimethyl ether as a complexing agent, allowing a scaling up of the CO<sub>2</sub> insertion reaction starting from 10 g of reacting epoxides.<sup>[25-29]</sup> In the light of these results, as a part of our long standing interest in sustainable CF reactions,<sup>[30-33]</sup> we were prompted to investigate whether mixtures of organic ligands based on oligo- and poly-glycols and alkali/alkaline earth metal halides, could be used for the preparation of COCs in CF mode. This was a substantially unexplored area with major challenges associated to the control of the viscosity of the complexing agent and the design of a liquid/gas biphasic system able to ensure reactants/catalyst miscibility and suitable contact time for the process. We report here that CO<sub>2</sub> insertion in model epoxides succeeded by using a diethylene glycol (DEG)/NaBr catalytic system. DEG was chosen as a model hydrogen bond donor moiety due to its ability to coordinate Na<sup>+</sup> cations. After an initial screening on the effects of reaction parameters in batch conditions (in an autoclave), the reaction was implemented in the continuous mode by making a homogenous mixture of DEG, NaBr and the selected epoxide flow through a capillary steel column (the CF-reactor), under controlled flow/pressure of CO<sub>2</sub>. At T= 140 - 220 °C and p(CO<sub>2</sub>) = 120 bar, conversions of the tested epoxides (styrene oxide, SO; butyl glycidyl ether, BGE and 1,2-epoxyhexane, EO) ranged from 75 to > 99 %, and the corresponding COCs were achieved with selectivity up to 93 %. The CF-setup proved robust and flexible since the products were separated by continuous extraction at the reactor outlet, while the (homogenous) catalyst as a DEG/NaBr mixture was recovered and reused.

## Results and Discussion

### Batch conditions

*Choice of complexing agent (co-catalyst).* The insertion of CO<sub>2</sub> into styrene oxide (**1a**: SO) was chosen as a model reaction to investigate in the presence of NaBr as the catalyst and different glycols and alcohols as co-catalysts/complexing agents. Diethylene glycol (DEG), diethylene glycol dimethyl ether (DEGDME) 1-hexanol and 1,6-hexanediol were tested. With the aim to preliminarily explore the effects of reaction parameters, initial experiments were carried out in the batch mode. A steel pressure vessel (autoclave, 200 mL) was charged with a homogenous solution of SO (0.4 g, 3.33 mmol), NaBr and the selected glycol in SO/NaBr/glycol 1:0.1:0.3 molar ratio. The mixture was then heated at 50-100 °C under 40 bar of CO<sub>2</sub>, under magnetic stirring. Results are summarized in Table 1 which reports the conversion of SO and the yield of styrene carbonate (SC: 4-phenyl-1,3-dioxolan-2-one) determined after 5 h. Hexanol, 1,6-hexanediol and the methyl capped-glycol (DEGDME) offered poor reaction conversions not exceeding 12, 14 and 3 % at T = 100 °C, respectively (Entries 1-3, Table 1). By contrast, quantitative and exclusive formation of SC was achieved when DEG was used as a co-catalyst (entry 6). Diethylene glycol proved active even at temperatures between 50 and 70 °C, albeit with lower conversions (21 and 62%, respectively: entries 4-5). These comparative experiments demonstrated the superior performance

## FULL PAPER

of DEG suggesting that its structure was particularly suited for the complexation and activation of NaBr and the reactant epoxide. To the best of our knowledge, the use of DEG/NaBr was an unprecedented combination to promote CO<sub>2</sub> insertion reactions. The study of this mixture was continued at 100 °C.

**Table 1.** CO<sub>2</sub> insertion in SO catalyzed by NaBr/glycol: effects of the co-catalyst and the temperature under batch conditions

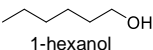
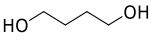
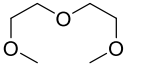
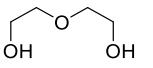
Entry	Co-catalyst	T (°C)	Yield <sup>[a],[b]</sup>
1	 1-hexanol	100	12
2	 1,6-hexanediol	100	14
3	 DEGDME	100	3
4	 DEG	50	22
5	DEG	75	63
6	DEG	100	99

All reactions were carried out for t = 5 h in an autoclave charged with a mixture of SO (3.33 mmol), NaBr and the co-catalyst in a 1:0.1:0.3 molar ratio, respectively. [a] Yields were determined by GC using mesitylene (10 % mol) as an internal standard. [b] Selectivity were always > 99% according to GC and <sup>1</sup>H NMR analysis.

**Effects of reaction time, reactant:catalyst molar ratio, and CO<sub>2</sub> pressure.** A series of experiments was carried out at 100 °C by changing one at a time, the reaction parameters of Table 1, specifically by decreasing: i) the reaction time (t) from 5 to 3 and 2 h, respectively; ii) the SO:NaBr:DEG molar ratio (W) from 1:0.1:0.3 to 1:0.05-0.025:0.3 and then 1:0.1:0.2 and finally, in the absence of either DEG or NaBr; iii) the CO<sub>2</sub> pressure from 40 to 10, 2 and 1 bar. In the latter case (1 bar = atmospheric pressure), the CO<sub>2</sub> insertion process was carried out in a conventional glass flask (50 mL) equipped with a 2 L CO<sub>2</sub> reservoir (see Figure S1 in SI section for further details). All reactions were run in duplicate for reproducibility ensuring <5% difference in conversion and selectivity between repeated tests. The results are reported in Table 2.

Compared to the 5 h tests of Table 1, 3 h were sufficient for quantitative reactions, while a slight decrease of the conversion (from 99 to 96%) was noticed after 2 h (Entries 1-3, Table 2). Further experiments were conducted on this basis (3 h). A pronounced effect, particularly on the extent of the SO conversion, was observed by varying the reactant/catalyst/DEG molar ratio. Indeed, when the catalyst (NaBr) was reduced from 10 to 5 mol % and then to 2.5 mol%, the conversion of the epoxide dropped from 99 to 62 and 20%, respectively (Entries 2, 4 and 5, Table 2). This clearly indicated the role of the halide salt concentration in the process kinetics, pointing out how the bromide-mediated ring opening of the epoxide was the rate-determining step of the overall CO<sub>2</sub> insertion process. In line with this observation,

decreasing the loading of the co-catalyst (DEG) from 30 to 20 mol % caused a reduction of the SO conversion, from 99 to 85%, (Entries 2 and 6, Table 2) consistent with a lower bromide activation. In addition, DEG could assist the reaction through its hydrogen bond donor activity, making the epoxide ring cleavage easier (see later, Figure 2). The synergic action of the catalyst and the co-catalyst was unambiguously proved by the tests in the absence of either NaBr or DEG where no reaction took place (Entries 7 and 8, Table 2). Conditions investigated so far suggested that the best results were achieved using the mixture of SO, NaBr, and DEG in the W= 1:0.1:0.3 molar ratio, respectively. This (W) ratio was set to study the pressure effect. Experiments demonstrated that the reaction outcome was not affected by the pressure over the range 1-40 bar, wherein SO was quantitatively converted into styrene carbonate (Entries 9-11, Table 2). In agreement with Figure 1, CO<sub>2</sub> insertion was apparently much faster compared to the RDS (rate determining step), i.e. epoxide ring opening.

**Table 2.** CO<sub>2</sub> insertion into styrene oxide catalyzed by NaBr/DEG: effects of reaction time, reactant:catalyst molar ratio, and CO<sub>2</sub> pressure.

Entry	p <sup>0</sup> (CO <sub>2</sub> ) (bar)	t (h)	SO:NaBr:DEG (mol/mol)	Yield <sup>[a],[b]</sup>
1	40	5	1:0.1:0.3	>99
2	40	3	1:0.1:0.3	>99
3	40	2	1:0.1:0.3	96
4	40	3	1:0.05:0.3	62
5	40	3	1:0.025:0.3	23
6	40	3	1:0.1:0.2	86
7	40	3	1:0:0.3	0
8	40	3	1:0.1:0	0
9	10	3	1:0.1:0.3	>99
10	2	3	1:0.1:0.3	>99
11	1	3	1:0.1:0.3	>99

All reactions were carried out at 100 °C, in an autoclave charged with a mixture of SO (3.33 mmol), NaBr and DEG in the reported molar ratio. [a] Yields were determined by GC using mesitylene (10 % mol) as an internal standard. [b] Selectivity were always > 99% according to GC and <sup>1</sup>H NMR analysis

A plausible mechanistic hypothesis for catalyst activation by DEG is shown in Figure 2. Diethylene glycol plausibly played a double role acting as a chelating agent for Na<sup>+</sup> but also as a hydrogen bond donor (HBD) that assisted the ring-opening of the reactant epoxide. Both the complexing and HBD activity of polyethylene glycols are indeed widely reported. <sup>[23-28, 34]</sup>

Overall, Tables 1 and 2 show that an effective and robust batch synthesis of styrene carbonate was achieved. These results were further examined by assessing the performance of NaBr/DEG with respect to that of 7 other recently reported halide-based catalysts, with characteristics in terms of commercial availability and ease of handling comparable to our system. These included combination of iodide salts (KI and CaI<sub>2</sub>) with polyethylene glycols,

## FULL PAPER

crown ethers,  $\beta$ -cyclodextrin, polyvinyl alcohol, etc. Albeit the range of operating conditions was widely variable (T, p, and t from 25 to 140 °C, 1 to 60 bar, and 3 to 48 h, respectively), on balance, the DEG/NaBr mixture was equally, if not more, active and economic than other systems. (Details are in the SI section, Table S1).

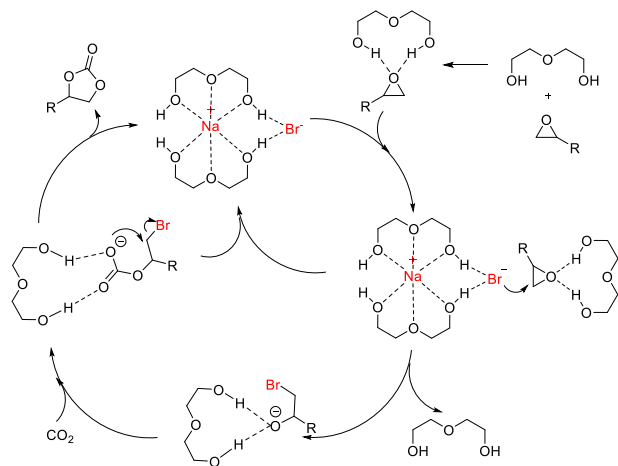

**Figure 2.** Proposed mechanism for the co-catalytic effect of DEG. Top, mid: the activation of NaBr; top-to-bottom, right: hydrogen bond donor assistance to the epoxide ring cleavage.

**Substrate scope.** Under the best conditions for the conversion of SO (Entries 2 and 11, Table 2), the activity of the binary mixture of NaBr/DEG was tested for 6 other terminal epoxides including 1,2-epoxybutane (**1b**), 1,2-epoxyhexane (**1c**), 1,2-epoxydecane (**1d**), butyl glycidyl ether (**1e**), phenyl glycidyl ether (**1f**), and 1,4-butanediol diglycidyl ether (**1g**). Reactions were carried out at T = 100 °C for t = 3 h, using a solution of the epoxide, NaBr, and DEG in a 1:0.1:0.3 molar ratio, respectively. Experiments were performed at both  $p^0(\text{CO}_2) = 40$  bar and atmospheric pressure. All the tested epoxides were quantitatively and selectively converted into the corresponding COCs (**2b-g**), (Scheme 2), thereby confirming that: i) the batch protocol could be extended to a range of different epoxides; ii)  $\text{CO}_2$  insertion reactions were not substantially affected by the  $\text{CO}_2$  pressure. In the case of the di-epoxide **1g**, the bis-cyclic carbonate **2g** was obtained.

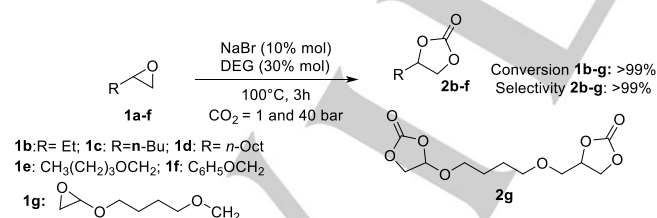

**Scheme 2.** NaBr/DEG catalyzed  $\text{CO}_2$  insertion in terminal epoxides: substrate scope. Conversion and selectivity were determined by GC in the presence of mesitylene as internal standard.

The batch protocol was also examined using the internal epoxide of methyl oleate, i.e. methyl 8-(3-octyloxiran-2-yl) octanoate (**1h**) in its pure diastereomeric cis form. Under the conditions of Scheme 2, the reaction conversion was 66% and the selectivity to the carbonate derivative, methyl 8-(5-octyl-2-oxo-1,3-dioxolan-4-yl) octanoate (**2h**), was 50% (60:40 cis/trans). The only observed

by-product (16%) was methyl 9-oxooctadecanoate coming from a known isomerization process of the starting epoxide,<sup>[35]</sup> (Scheme 3).

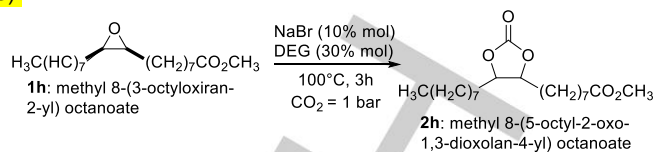

**Scheme 3.** NaBr/DEG catalyzed  $\text{CO}_2$  insertion in the internal epoxide **1h**. Conversion and selectivity were determined by GC in the presence of mesitylene as internal standard.

Under the reaction conditions, the cis-epoxide plausibly underwent the formation of trans-epoxidized methyl oleate which accounted for the presence of the carbonate **2h** product in a 60:40 cis/trans mixture.

Carbonate products were characterised by  $^1\text{H}$ - and  $^{13}\text{C}$ -NMR and GC/MS (details are reported in the SI section, Figures S7-S27).

### Continuous Flow (CF)

**CF-setup.** The encouraging results obtained investigating the  $\text{CO}_2$  insertion in batch mode prompted us to extend the protocol under continuous-flow conditions. Flow chemistry is one of the top ten emerging technologies with high potential for sustainable syntheses,<sup>[36,37]</sup> yet, from a chemical engineering standpoint, the transfer from a batch to a continuous process poses some issues especially when a setup comprised of a polar liquid mixture and nonpolar (gaseous or liquid/supercritical)  $\text{CO}_2$  are present as in the case of this work. We focused on two main aspects: i) identification of a liquid carrier (solvent) to achieve a homogeneous solution of epoxide, NaBr and DEG and with low enough viscosity for continuous pumping for extended time; ii) design of an experimental setup with full control of liquid and  $\text{CO}_2$  flows (i.e. pressure/contact time) able to ensure miscibility of all the components (reactants/catalyst/co-catalyst/ $\text{CO}_2$ ). A comparative study of different solvents including toluene, THF, chloroform, 2-butanone, acetonitrile and DEG proved that the latter (DEG) was not only an excellent complexing agent, but it could also act as the best reaction medium. Moreover, DEG was directly involved in the catalytic process via epoxide coordination to its Brønsted acid moieties (Figure 2). Details of this investigation are reported in the SI section, where Table S2 and Scheme S1 compare  $\text{CO}_2$  insertions carried out using a 5M solution of the reactant epoxide (SO, BGE, and EHx) in each of the tested solvent. Based on our expertise in flow chemistry,<sup>[32,33,38]</sup> the CF-apparatus was designed and in-house assembled, using a microfluidic reactor in the shape of 1/16" stainless-steel coil (Figure 3).  $\text{CO}_2$  was supplied as a liquid from a commercial  $\text{CO}_2$  cylinder equipped with a dip tube and then compressed at the desired pressure and flow by a refrigerated dual head pump ( $P_{\text{CO}_2}$ ). The solution of epoxide, NaBr and DEG was delivered by an HPLC pump ( $P_{\text{L}}$ ). The  $\text{CO}_2$  and liquid streams were mixed in T junction (T) and conveyed to the CF-reactor (coil C) placed inside an oven for the temperature control. A back-pressure regulator (BPR) maintained a constant operating pressure throughout the system and allowed the depressurization and recovery of the reaction mixture in the extractor (E) where the

## FULL PAPER

COC product was separated from the NaBr catalyst and DEG co-catalysts which were recycled (*vide infra*).

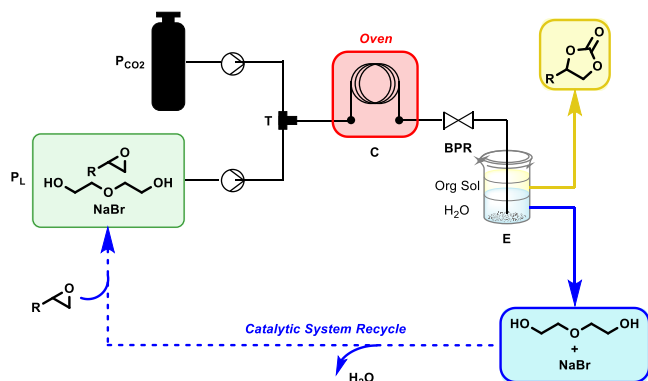

**Figure 3.** CF apparatus used for CF CO<sub>2</sub> insertion into epoxides

The CF insertion of CO<sub>2</sub> into 1,2-epoxyhexane (**1c**). Compound **1c** was chosen as a model terminal epoxide to begin the study of CF CO<sub>2</sub> insertions, due to its relatively low toxicity and reduced the risks associated to its use in CF systems under pressure. Experiments were carried out using a 1 M solution of **1c** in DEG in the presence of NaBr (0.1-1 molar equiv. with respect to **1c**). This mixture was fed along with CO<sub>2</sub> to the CF-reactor of Figure 3: for screening tests, the dimensions of the steel coil were 2500 x 0.2 mm (length x internal diameter; 7.85·10<sup>-2</sup> cm<sup>3</sup> internal volume). Check valves were placed to avoid cross-contamination. All tests were run for t = 2 h by changing different pressure, temperature, and flow rates of the liquid solution (F<sub>L</sub>) and CO<sub>2</sub> (F<sub>CO2</sub>) stream in the range of 60-150 bar, 150-220 °C, 0.1-1.0 mL min<sup>-1</sup>, and 1.0-4.0 mL min<sup>-1</sup>, respectively. GC and GC-MS analyses of reaction mixtures samples confirmed the formation of 3 different products: hexene carbonate (**2c**), 1-bromohexan-2-ol (**3c**: BHO), and hexane-1,2-diol (**4c**) (Scheme 4).

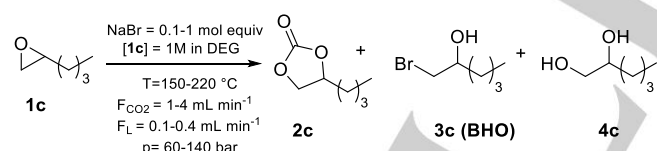

**Scheme 4.** The CO<sub>2</sub> insertion in EHx in the presence of NaBr/DEG under CF conditions

According to the mechanism of Figure 1, the bromohydrin (**3c**: BHO) was the reaction intermediate formed by the nucleophilic attack of the bromide anion to the primary carbon atom of the epoxide ring, as confirmed by GC-MS and NMR (see SI for further details, Figures S4 and S5). Formation of the diol **4c** (MS spectrum in Figure S6) was due to hydrolysis of the starting epoxide plausibly promoted by traces of water in the highly hygroscopic DEG.<sup>[39]</sup> For the recovery of the products of Scheme 3, the simplest method was to convey the reaction mixture to a separatory flask containing a biphasic system of water and an organic solvent (30 mL of each phase). Five different solvents including diethyl ether, diethyl carbonate, cyclopentyl methyl ether (CPME), *n*-hexane and ethyl acetate were tested and compared to this purpose. Diethyl carbonate (DEC) was finally chosen for its suitability for carbonate products and its low toxicity and safety (details on the procedure are reported in the SI section).

The unconverted reactant and the products were extracted in DEC, while the catalyst/co-catalyst (NaBr/DEG) were quantitatively dissolved in the aqueous solution (Figure 3). All tests were run in duplicate for reproducibility: in repeated reactions, conversion and selectivity differed <5% from one experiment to another. Results are reported in Table 3. The reaction outcome depended on multiple parameters such as temperature, reactant/NaBr (Q) molar ratio, flow rate, and CO<sub>2</sub> pressure. At the lowest investigated pressure, Q ratio and flow rates (60 bar, F<sub>L</sub> = 0.1 and mL·min<sup>-1</sup>, F<sub>CO2</sub> = 1 mL min<sup>-1</sup> and Q = 0.2), the epoxide conversion was very low at T = 150 °C (8 %) and it was limited even at T = 200 °C, not exceeding 15 % (Entries 1 and 2, Table 3). Formation of the desired COC product, 4-butyl-1,3-dioxolan-2-one (**2c**), was also unsatisfactory (up to 13 %), because of the predominant presence of the bromohydrin intermediate (BHO, 80 %). Doubling the system pressure up to p = 120 bar had a modest influence: the corresponding epoxide conversion and selectivity to **2c** were 18 and 19 %, respectively (Entry 3, Table 3).

Further testing showed that significant improvements of the reaction outcome could be reached through the cooperative effects of T and the Q ratio variation. This was exemplified by the results of Entries 4 and 5, Table 3: at p = 120 bar, when the temperature and the catalyst loading were progressively raised from 200 to 220 °C and from 0.1 to 0.3 and 1 molar equiv., respectively, the epoxide conversion also increased from 18 to 25 and 88% and the carbonate selectivity was enhanced to 81% (Entry 5, Table 3). Under such conditions, an effect of the pressure was also noticed: albeit an increase to p = 140 bar did not produce appreciable changes, a decrease to p = 100 bar brought about a 9 % reduction of the conversion (from 90 to 82%, compare Entries 6 and 7, Table 3). Minor variations of products distribution were observed. The CF system pressure, therefore, must be set at a sufficiently high threshold value (p ≥ 120 bar) to ensure a constant CO<sub>2</sub> concentration in the reaction environment. In light of these results, the study was continued choosing T, p, and Q (NaBr:**1c** molar ratio) of 220 °C, 120 bar, and 1, respectively. A partial thermal degradation of DEG was noticed above 220 °C resulting in clogging of the CF-reactor. Therefore, temperatures > 220 °C were not explored. Further considerations on the thermal stability of DEG and carbonate products were reported in the SI section.

The influence of changing the flow rate of both the reactant solution (F<sub>L</sub>) and CO<sub>2</sub> (F<sub>CO2</sub>) stream was then investigated. Experiments were first carried out by increasing F<sub>L</sub> from 0.1 to 0.2 and 0.4 mL·min<sup>-1</sup>, at a constant F<sub>CO2</sub> (1 mL min<sup>-1</sup>). No apparent effects on the reaction outcome were noticed (Entries 5 and 8-9, Table 3). The reaction productivity [defined as moles of carbonate product · (h · cat. equiv)<sup>-1</sup>], however, was substantially enhanced: by quadrupling F<sub>L</sub>, the rate of EHxC formation went up from 4.3 mmol h<sup>-1</sup> equiv<sup>-1</sup> to 15.9 mmol h<sup>-1</sup> equiv<sup>-1</sup> with an increase by a factor of 3.7. When F<sub>L</sub> was further raised to 1 mL min<sup>-1</sup>, a drop of both the conversion (73 %) and the carbonate selectivity (63 %) was observed (Entry 10, Table 3); yet, the productivity continued to increase up to 27.6 mmol h<sup>-1</sup> equiv<sup>-1</sup>. No further investigations were carried out in this respect, but it should be noted here that under batch conditions, the maximum productivity for carbonate **2c** was 11.1 mmol h<sup>-1</sup> equiv<sup>-1</sup> (Scheme 2), about 2.5-fold lower than that in the CF-mode.

Increasing  $F_{\text{CO}_2}$  from 1 to 4 mL min<sup>-1</sup> (at constant  $F_L = 0.1$  mL min<sup>-1</sup>) was also detrimental for the epoxide conversion, which was reduced from 88 to 69 % (compare Entries 5 and 11, Table 3). These findings highlighted how the feeding rates of the liquid solution ( $F_L$ ) and of supercritical  $\text{CO}_2$  ( $F_{\text{CO}_2}$ ) affected the CF

reaction: higher flow rates resulted in lower contact times, lower epoxides conversion and lower COC selectivity. Overall, the concept was proved: the  $\text{CO}_2$  insertion into **1c** could be engineered to proceed in CF mode in the presence of a homogenous catalyst/co-catalyst system (NaBr/DEG).

**Table 3.** Synthesis of carbonate **2c** (hexylene carbonate) from 1,2-epoxyhexane (**1c**) and  $\text{CO}_2$  in the continuous mode. Effects of key reaction parameters

Entry	<b>1c</b> :NaBr (Q, mol:mol)	$F_L/F_{\text{CO}_2}$ (mL/min)	$p$ (bar)	$T$ (°C)	Conv. (%) <sup>[a]</sup>	Sel. (%) <sup>[a]</sup>		
						<b>2c</b>	<b>3c</b>	<b>4c</b>
1	0.1	0.1/1	60	150	8	-	>99	-
2	0.1	0.1/1	60	200	15	13	80	7
3	0.1	0.1/1	120	200	18	19	74	7
4	0.3	0.1/1	120	200	25	26	67	7
5	1	0.1/1	120	220	88	81	15	4
6	1	0.1/1	140	220	90	82	15	3
7	1	0.1/1	100	220	82	79	18	4
8	1	0.2/1	120	220	88	78	17	5
9	1	0.4/1	120	220	84	79	16	4
10	1	1/1	120	220	73	63	30	7
11	1	0.1/4	120	220	69	77	19	4

All reactions were run for  $t = 2$  h. <sup>[a]</sup> Conversion and selectivity were determined by GC-MS analysis

Two major challenges remained open: i) devising a purification protocol to allow an efficient separation of products, while effectively recycling the NaBr/DEG “catalytic” mixture; ii) improving the formation of the carbonate product (**2c**). None of the changes of reaction parameters in Table 3 was effective in this respect: the selectivity to compound **2c** apparently levelled off, never exceeding 82 %, mainly because of the formation of the BHO intermediate which persisted in the final reaction mixtures. The selectivity to the diol (**4c**) showed instead, a general decreasing trend from 7% to 3-4% as the epoxide conversion increased from ca 20 to >80%, respectively.

**Catalytic system recycling and mass balance.** Experiments on the recycling of the NaBr/DEG system were carried out under the experimental conditions of Entry 5, Table 3 (**1c**) = 1 M in DEG; NaBr (1.0 equiv.);  $F_L = 0.1$  mL·min<sup>-1</sup>,  $F_{\text{CO}_2} = 1$  mL·min<sup>-1</sup>,  $p = 120$  bar,  $T = 220$  °C), as summarized in Scheme 5.

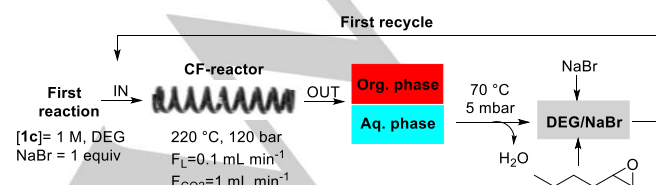

**Scheme 5.** Catalytic system recycling in CF-mode

In a typical setup, a CF-reaction was allowed to proceed for  $t = 2$  h and continuously collected at the reactor outlet by venting it in a biphasic mixture consisting of diethyl carbonate and water (Figure 3). The catalytic system (DEG and NaBr) present exclusively in the aqueous layer, was collected and evaporated under reduced pressure ( $T = 70$  °C,  $p = 5$  mbar) until complete removal of water. To the resulting liquid was added fresh epoxide (**1c**: 12 mmol to obtain a 1 M solution in DEG) and an additional aliquot of NaBr (163 mg, 1.6 mmol). The latter was necessary to integrate the amount of catalyst consumed by the formation of the bromohydrin intermediate (**3c**: BHO), and it was calculated to restore the initial quantity of NaBr (*i.e.* to achieve an epoxide:catalyst molar ratio of 1, based on 88% conversion and 15% selectivity towards BHO, see Entry 5, Table 3). A similar topping-up procedure was reported for  $\text{CO}_2$  insertion in epoxides also in the presence of dual component organocatalysts based on pyrogallol and onium iodides.<sup>[40]</sup> The solution was then delivered to the CF-reactor for the first recycle run. The steps of Scheme 4 were repeated for 4 subsequent recycles. The amount of fresh NaBr was adjusted after each experiment according to the conversion and the selectivity achieved case-by-case. Results are reported in Figure 4.

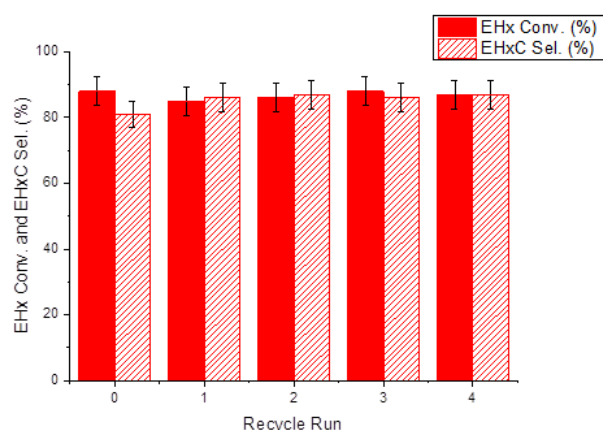

**Figure 4.** DEG/NaBr system recycling upon CF synthesis of hexylene carbonate (**2c**). Conditions: [**1c**] = 1 M in DEG, NaBr:**1c** = 1.0 mol/mol;  $F_L = 0.1 \text{ mL}\cdot\text{min}^{-1}$ ,  $F_{\text{CO}_2} = 1 \text{ mL}\cdot\text{min}^{-1}$ ,  $p = 120 \text{ bar}$ ,  $T = 220 \text{ }^\circ\text{C}$ . Run 0 (first reaction) refers to the result of Entry 5, Table 3

After each recycle, both the conversion and EHxC selectivity were substantially steady at ca 85-90% and 80-85%, respectively, thereby proving that the NaBr/DEG catalytic mixture was reusable without loss of performance. It should be noted however, that undesired hydrolysis of the alcoholate precursor of the bromohydrin intermediate (Scheme 6), produced NaOH as by-product which accumulated in the DEG solution, making it denser and (slightly) more viscous after each cycle.

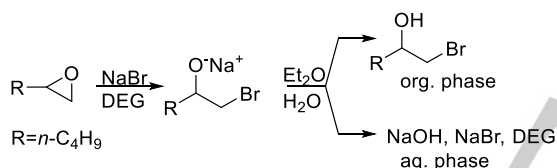

**Scheme 6.** Hydrolysis of the alcoholate precursor of bromohydrin

Although this feature was not investigated in detail, nor its consequences were apparent from Figure 3, nevertheless it could plausibly bring about a limitation in view of an indefinite recycle of the DEG solution: the higher its viscosity/density, the more difficult the mass transport, especially in microfluidic reactors.<sup>[41]</sup> Moreover, part of NaBr was irreversibly consumed in each reaction run.

Recycle experiments allowed to confirm the reaction mass balance. To this aim, the organic phase (containing exclusively the products) was collected and concentrated *in vacuo* ( $T = 30 \text{ }^\circ\text{C}$ ,  $p = 50 \text{ mbar}$ ) and dried. The desired product, EHxC was then isolated by FCC, with isolated yields ranging between 66 and 71 %, consistent with the conversion and selectivity reported in Table 3 and Figure 3 (see SI for further details, Table S4).

*Improving the selectivity: effect of reactor length (contact time) and substrate scope.* Previous experiments highlighted that the selectivity towards the EHxC product was mostly limited by formation of BHO. Increasing the contact (residence) time could plausibly favour the conversion of BHO into hexylene carbonate **2c**. However, the technical specs of the pumps of our CF system did not allow flow rates lower than the values specified in Table 3 ( $F_L = 0.1 \text{ mL}\cdot\text{min}^{-1}$  and  $F_{\text{CO}_2} = 1 \text{ mL}\cdot\text{min}^{-1}$ ). A redesign of the CF reactor was therefore required. The same 1/16" steel coil (internal

diameter = 0.2 mm) of Figure 3 was used, but the reactor length and internal volume were doubled from 250 to 500 cm, and from  $7.85 \cdot 10^{-2}$  to  $0.157 \text{ cm}^3$ , respectively. Experiments were performed under the conditions of Entry 5, Table 3 ([**1c**] = 1 M in DEG; NaBr (1.0 equiv.);  $F_L = 0.1 \text{ mL}\cdot\text{min}^{-1}$ ,  $F_{\text{CO}_2} = 1 \text{ mL}\cdot\text{min}^{-1}$ ,  $p = 120 \text{ bar}$ ,  $T = 220 \text{ }^\circ\text{C}$ ). Epoxides **1c** and **1e** (butyl glycidyl ether) were set to react in both the available reactors of 250 and 500 cm; while, two additional tests were run with epoxides **1f** and **1g** using only the longer coil (500 cm). Results are reported in Table 4, which compares the conversion and the selectivity towards the desired COC products (**2**) and the corresponding bromohydrins (**3**). When choosing **1c** as a model substrate, increasing the reactor length improved the conversion from 88 to 92%, but had an even more pronounced effect on the selectivity towards the desired hexylene carbonate (**2c**) which increased from 81 to 91% (Entries 1 and 2, Table 4). The diol (**4c**: hexane-1,2-diol in Scheme 3) was not detected, not even in trace levels (compare Entries 1 and 2, Table 4); this result was consistent with the correlation previously noticed in Table 3, between the diol selectivity and the epoxide conversion. Apparently, the initially formed **4c** gradually disappeared if the CF-reaction was allowed to proceed at high conversion (>90%), thereby suggesting that even the diol could transform into carbonate **2c** via direct addition of  $\text{CO}_2$  and dehydration. Albeit thermodynamically disfavored, this last sequence (addition/dehydration) has been described under a range of different conditions.<sup>[29]</sup> A similar outcome was observed when performing CF  $\text{CO}_2$  insertion reactions on epoxide **1e**: increasing coil length resulted in a quantitative conversion with an excellent selectivity to the corresponding COC **2e** (93%, entry 4). These results supported the mechanism of Figure 2 since the increase of the carbonate product at the expenses of the bromohydrin clarified the role of the bromohydrin itself as a reaction intermediate. Finally, using phenyl glycidyl ether and 1,4-butanediol diglycidyl ether (**1e** and **1f**) as reactants, conversions were quantitative with excellent carbonate selectivity in both cases (>99%: entries 5 and 6). This general improvement of the reaction outcome positively impacted also on the DEG/NaBr recycling, reducing if not avoiding topping-up of the catalyst. Indeed, once the reaction run under conditions of entry 4 was complete, a successful recycle test was carried out by integrating NaBr of an amount (85 mg) equal to only 7% of its initial loading: the observed conversion of **1e** and selectivity to the carbonate **2e** were 99% and 92%, respectively. A similar effective recycle was achieved even after the reaction of epoxide **1f** in entry 5, though, in this case, no addition (integration) of fresh catalyst was necessary since the process was quantitative and the corresponding bromohydrin intermediate was not observed at all. Overall, the CF system could be flexibly engineered by adjusting the length of the CF reactor to overcome issues associated to the kinetics of the consecutive reactions involved (bromohydrin and  $\text{CO}_2$  insertion). A more quantitative explanation of these results should have considered the estimation and comparison of the contact time under the investigated conditions. This was beyond the scope of the present paper: a flowing system comprising a polar liquid (epoxide in DEG/NaBr) and a non-polar supercritical gas-like phase ( $\text{CO}_2$  with a density as low as  $0.14 \text{ g}\cdot\text{mL}^{-1}$  at  $220 \text{ }^\circ\text{C}$  and 120 bar) made this study challenging, if at all possible.<sup>[42,43]</sup>

Additional experiments were performed using also styrene oxide (**1a**: SO). In this case, however, the onset of a competitive

## FULL PAPER

isomerization side-reaction due to Meinwald rearrangement of SO did not allow to increase the selectivity towards styrene carbonate above 73 % even when with longer coils. Details of this study are reported in the SI section (Table S5).

**Table 4.** CO<sub>2</sub> insertion reactions in terminal epoxides: influence of CF reactor length.

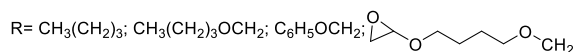
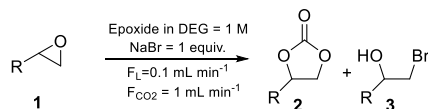

Entry	Epoxide	CF-reactor length (mm)	T (°C)	Conv (%)	Product Sel. (%)	
					2	3
1	1c	250 <sup>[a]</sup>	220	88	81	15
2		500		92	91	9
3	1e	250	220	95	85	15
4		500		99	93	7
5	1f	500	220	>99	>99	
6	1g	500	220	>99	>99 <sup>[b]</sup>	

t = 2 h for all reactions. Conversion and selectivity were determined by GC-MS analysis. <sup>[a]</sup> Result of entry 5 in Table 1: hexane-1,2-diol (4c: 4%) was also detected among reaction products. <sup>[b]</sup> The bis-cyclic carbonate 2g was the final product.

#### Comparison with other protocols for CO<sub>2</sub> insertion into epoxides.

A comparative assessment of the present procedure with other methods was carried out by selecting two recent representative papers that report effective catalytic systems and even more importantly, that describe in detail applications on CO<sub>2</sub> insertion into terminal epoxides under batch conditions and in continuous flow.<sup>[44,45]</sup> Table 5 shows the data examined in this comparison. The discussion was divided in three sections [(i)-iii)] for convenience.

*i) Catalysts.* Ref. [40] proposed catalysts based on melamine-formaldehyde resins (MFRs) prepared by sol-gel hydrothermal polymerizations, while ref. [40] described silica supported ionic liquids (both chemo- and physi-sorbed as SILC and SILP, respectively). Albeit different, both these approaches implied preparation/characterization steps and reproducibility control, increasingly challenging for large scale syntheses. No to mention the use of harmful chemicals as paraformaldehyde and ionic liquids, and the catalysts deactivation by build-up of products especially during long-term (on-stream) operations in flow mode. Such drawbacks could be by-passed by using the system investigated in the present work which was effectively a homogenous catalytic one based on inexpensive, sustainable, and commercially available NaBr and glycol. Catalyst deactivation was also not an issue since the NaBr/DEG mixture was continuously recovered by a simple green extraction with diethylcarbonate and re-used. Refs [44] and [45] did not consider recycling probably due to an energy and resource intensive recovery processes.

*ii) Productivity and substrate scope.* From the sustainability standpoint, the comparison of the productivity of different protocols is a complex issue since it should include aspects dealing with life cycle, from the synthetic step, to the preparation of catalyst and its recycle, the disposal and associated costs. In the absence of these details, simpler and more direct indicators were taken into account: both the total productivity (TP) defined as the grams of carbonate produced per hour (g·h<sup>-1</sup>) and the specific productivity (SP) referred to the mass unit (g) of catalyst were examined. Except for the reaction of epichlorohydrin (an extremely reactive substrate not investigated in the present work), the analysis indicated that for alkyl or aryl substituted terminal epoxides (R=CH<sub>3</sub>, CH<sub>3</sub>CH<sub>2</sub>, CH<sub>3</sub>(CH<sub>2</sub>)<sub>3</sub>OCH<sub>2</sub>, C<sub>6</sub>H<sub>5</sub>OCH<sub>2</sub>, *n*-C<sub>4</sub>H<sub>9</sub>, and C<sub>6</sub>H<sub>5</sub>) our protocol allowed comparably better results than the others. Under batch conditions, the average TP and SP of the NaBr/DEG system were 0.16-0.19 g·h<sup>-1</sup> and 4.71-5.29 g·(g<sub>cat</sub>h)<sup>-1</sup> (Entries 1-4, Table 5), well over those calculated for MFRs and ILs based catalysts (0.08-0.12 g·h<sup>-1</sup> and 0.37-2.4 g·(g<sub>cat</sub>h)<sup>-1</sup>, cfr. Entries 8-10 and 13, Table 5); in the flow mode, albeit TP was of the same order of magnitude for the different procedures, SP was more 3-times higher for NaBr/DEG with respect to other catalysts (Entries 5-7: TP=0.73-0.96 g·h<sup>-1</sup>, SP = 1.18-1.56 g·(g<sub>cat</sub>h)<sup>-1</sup>; Entries 11-12 and 14-15: TP = 0.69-0.93 and 0.50-0.68 g·h<sup>-1</sup>, SP = 0.35-0.47 and 0.37-0.51 g·(g<sub>cat</sub>h)<sup>-1</sup>). The intrinsic reactivity of different epoxides could be co-responsible for some differences of productivity; however, the consistent comparison of the reaction of styrene oxide confirmed that NaBr/DEG was more efficient for the formation of styrene carbonate (cfr. Entries 1 and 9, Table 5).

*Reaction conditions.* For batch processes, MFRs and ILs systems required considerably higher pressure and longer reaction times of 20-50 bar and 18-24 hours compared to our catalyst that promoted quantitative reactions at atmospheric pressure in 3 hours. With respect to NaBr/DEG, SILP/SILC operated at a lower temperature (70 °C vs 100 °C), while MFRs were active at 140 °C; the corresponding catalyst loading (Epox:Cat weight ratio) were however twice and half, respectively, the amount of NaBr/DEG. The latter therefore proved most effective. This advantage was less evident in the flow reactions: albeit our CF-system was more productive and operated with a far lower CO<sub>2</sub> flow (2-15 times smaller), the use of NaBr/DEG necessitated a higher temperature (220 °C, entries 5-7) compared to other systems (120 °C, entries 11-12 and 14-15). As a general observation, this apparent discrepancy could be hardly ascribed to chemical restraints or limitations due to the nature of the DEG/NaBr mixture. Since our batch protocol was active under similar, if not milder conditions (T, p, t) than those used for other catalysts (Tables S1 and 5), the higher energy demand of CF-reactions was likely due to a still-unoptimized engineering of our CF-apparatus, particularly by a finer tuning of flow rates which were crucial to improve the contact of reactants and the kinetics. CO<sub>2</sub> consumption, which is often underestimated, should also be considered: for example, CF-procedures of entries 11-12 and 14-15 in Table 5 involve a large excess CO<sub>2</sub>, most of it being wasted implying environmental and economic burden.

On a final note, energetic issues associated to elevated reaction temperatures can be efficiently mitigated especially as the preparation scale is increased. Modern chemical plants always



integrate heat recovery or exchange necessary for reactions within heat sinks and the usage of excess heat as part of the cogeneration plants.<sup>[46]</sup> Pertinent to this context is the commercial Shell Omega process for the CF-production of ethylene glycol via CO<sub>2</sub> insertion in ethylene oxide followed by hydrolysis, which

exemplifies the relevance of both heat recovery and CO<sub>2</sub> recycle.<sup>[47]</sup>

**Table 5.** Comparison of different catalytic system in the CO<sub>2</sub> insertion

to epoxide under batch and continuous flow												
Entry	Catalyst (synthesis)	 Substrate:R	BATCH <sup>[a]</sup>		CONTINUOUS FLOW				Conv./Sel./Yield (%) <sup>[e]</sup>	TP (g/h) <sup>[f]</sup>	SP (g/g <sub>cat</sub> h) <sup>[g]</sup>	Rif
			Epx:Cat (wt%) <sup>[b]</sup>	T/p/t (°C/bar/h)	F <sub>l</sub> /F <sub>CO<sub>2</sub></sub> <sup>[c]</sup> (mL/min)	T/p (°C/bar)	CO <sub>2</sub> /Epx (v/v) <sup>[d]</sup>	Solv.				
1		Ph							>99/>99/>99	0.18	5.29	
2		CH <sub>3</sub> (CH <sub>2</sub> ) <sub>3</sub> O CH <sub>2</sub>	7-9	100/1/3					>99/>99/>99	0.19	5.59	
3	NaBr/DEG (none: commercial products)	<i>n</i> -C <sub>4</sub> H <sub>9</sub>							>99/>99/>99	0.16	4.71	
4		CH <sub>3</sub> CH <sub>2</sub>							>99/>99/>99	XX	XX	This work
5		<i>n</i> -C <sub>4</sub> H <sub>9</sub>							92/91/84	0.73	1.18	
6		CH <sub>3</sub> (CH <sub>2</sub> ) <sub>3</sub> O CH <sub>2</sub>			0.1/1	220/120	71-83	none	99/93/92	0.96	1.56	
7		C <sub>6</sub> H <sub>5</sub> OCH <sub>2</sub>							>99/>99/>99	XX	XX	
8		CH <sub>3</sub> CH <sub>2</sub>		140/20/24					90/88/na	0.08	1.6	
9	Melamine formald. resins (solgel/ hydrotherm polym.)	Ph	2-3.5						88/99/na	0.12	2.4	
10		ClCH <sub>2</sub>		140/20/2					>99/>99/na	1.21	24.2	44
11		CH <sub>3</sub> CH <sub>2</sub>			0.01/15	120/13	150	none	86 <sup>[h]</sup> />99/na	0.69	0.35	
12		ClCH <sub>2</sub>							>99/>99/na	0.93	0.47	
13	Ionic liquids, SILC, SILP (surface modified silica with ILs)	CH <sub>3</sub>	16-18	70/50/18					na/na/99	0.11	0.37	
14		CH <sub>3</sub>			0.02/1.98	120/100	198	Hexane	na/na/65	0.50	0.37	45
15						120/160			na/na/89	0.68	0.51	

<sup>[a]</sup> No solvent used; <sup>[b]</sup> Epoxide:catalyst weight ratio. <sup>[c]</sup> F<sub>l</sub>: flow rate of liquid solution (epoxide+solvent); F<sub>CO<sub>2</sub></sub>: flow rate of CO<sub>2</sub>. <sup>[d]</sup> Epoxide:CO<sub>2</sub> volumetric ratio. <sup>[e]</sup> Conv.: conversion of the epoxide; Sel. and Yield: selectivity and yield on the corresponding carbonate product. <sup>[f]</sup> TP: total productivity of the protocol defined as grams of carbonate product obtained per hour (g/h). <sup>[g]</sup> SP: specific productivity defined as grams of carbonate product obtained per g of catalyst in an hour (g/g<sub>cat</sub>h). <sup>[h]</sup> Long-term performance due to catalyst deactivation. na= not available

## Conclusion

The current literature describes a limited number of examples reporting alkali metal halides as catalysts for CO<sub>2</sub> insertion into epoxides. This paper reports the first application of a simple non-polymeric glycol such as diethylene glycol (DEG) for the catalytic activation of NaBr in the insertion of CO<sub>2</sub> to terminal epoxides. The binary system made of NaBr/DEG has proven efficient for the batch conversion of different substrates including 7 terminal and one internal epoxides, but even more importantly, the characteristics of DEG (viscosity, density, diffusivity) made it suitable to act concurrently as a co-catalyst (cation coordinating agent and hydrogen bond donor) and a solvent/carrier for the implementation of the reaction in continuous-flow. However, translating the reaction conditions from batch to continuous flow

is challenging. The results gathered so far highlight that the batch reaction can be run under conditions far milder (T = 100 °C, p<sup>o</sup>(CO<sub>2</sub>) = 1 bar) than those required in CF-mode (T = 220 °C, p(CO<sub>2</sub>) = 120 bar); nevertheless, the potential of CF in terms of process intensification can be appreciated. Notably, in the explored range of flow rates, a microfluidic reactor with a capacity of just 7.85·10<sup>-2</sup> cm<sup>3</sup> allows a productivity 2.5 higher compared to the corresponding batch process carried out on a gram scale. Recycle experiments have also confirmed that the NaBr/DEG catalytic mixture is reusable without loss of performance, for at least four subsequent CF-runs. Moreover, a comparative analysis has proven that the NaBr/DEG system is competitive with other systems based on organic resins and ionic liquids, particularly regarding productivity, greenness, and possibly (economic) sustainability. A significant advance with respect to previous data is the continuous recyclability of the homogeneous mixture that

bypasses typical drawbacks associated to heterogeneous catalyst deactivation.

Although further optimization is required in terms of process engineering to improve the CF system design and maximize delivery/contact between the polar liquid solution of reactant/catalyst/co-catalyst and gas-like apolar supercritical CO<sub>2</sub>, the study provides a proof of concept which paves the way for future advances in the field.

## Experimental Section

**General.** Commercially available reagents and solvents were used as received unless otherwise stated. 1,2-epoxyhexane (hexene oxide, EHx), 2-phenyloxirane (styrene oxide, SO), 2-(propoxymethyl)oxirane (butyl glycidyl ether; BGE), diethylene glycol (DEG), ethanol, NaBr, diethylene glycol (DEG), diethylene glycol dimethyl ether (DEGME) 1-hexanol and 1,6-hexanediol were sourced from Sigma-Aldrich (now Merck). GC-MS (EI, 70 eV) analyses were performed with an Agilent 6890N GC, equipped with a HP5-MS capillary column (l = 30 m,  $\phi$  = 0.32 mm, film thickness = 0.25 mm), coupled with an Agilent 5975 EI detector. GC-FID analyses were performed with a HP 6890 GC mounting an Elite-624 capillary column (l = 30 m,  $\phi$  = 0.32 mm, film thickness = 1.8 mm). <sup>1</sup>H and <sup>13</sup>C NMR spectra were recorded with a Bruker Ascend 400 instrument operating at 400 and 100 MHz, respectively. The chemical shifts were reported downfield from tetramethylsilane (TMS). CDCl<sub>3</sub> and DMSO-d<sub>6</sub> were chosen as deuterated solvents.

**General procedure for CO<sub>2</sub> insertion reactions with terminal epoxides in batch conditions,** p<sup>0</sup>(CO<sub>2</sub>) = 10–50 bar. The selected epoxide (3.33 mmol, 1 equiv.), NaBr (0.025 – 0.1 eq), the co-catalyst (DEG, DEGME, 1-hexanol or 1,6-hexanediol, 0.2 – 0.3 eq), and mesitylene (0.33 mmol, 0.1 equiv., as the internal standard) were charged in a round-bottomed flask shaped as a test tube and equipped with a pierced glass cap and a stirring bar. The flask was placed inside a 100-mL stainless steel autoclave which was sealed, degassed via three vacuum-CO<sub>2</sub> cycles, pressurized with CO<sub>2</sub> (10–50 bar), and finally heated at T of 50–100°C for 2–5 h. Thereafter, the autoclave was cooled to rt and vented. A sample of the crude mixture was analysed by <sup>1</sup>H NMR to determine conversion, yield and selectivity.

**General procedure for CO<sub>2</sub> insertion reactions in CF conditions.** Reactions were performed using the apparatus of Figure 3. Experimental conditions were described throughout Table 3 and 4 and Figure 3. In a typical procedure, the CF apparatus was first conditioned with DEG (F<sub>L</sub> = 0.5 mL·min<sup>-1</sup>), and CO<sub>2</sub> (F<sub>CO2</sub> = 4 mL·min<sup>-1</sup>) for t = 30 min. Then, a homogeneous 1 M solution of the epoxide of choice (EHx, BGE, SO), and NaBr (0.1–1 equiv. with respect to the epoxide) in DEG was continuously delivered to the CF-reactor at the desired T and flow rates (T = 140–220 °C, F<sub>L</sub> = 0.1–0.4 mL·min<sup>-1</sup> and F<sub>CO2</sub> = 1–4 mL·min<sup>-1</sup>). Reactions were allowed to proceed for t = 2 h, though some prolonged tests were carried out for up to t = 6 h. The reaction mixture was collected according to the procedure exemplified by Figure S1 (see SI for further details). After each test, the CF system was washed with distilled water (10 mL) and ethanol (10 mL) and dried with a CO<sub>2</sub> flow (F<sub>CO2</sub> = 4 mL·min<sup>-1</sup>) for 10 minutes.

## Acknowledgements

Mr Riccardo Basso, Mr Nicola Bragato e Mr Michele Peruffo are kindly acknowledged for their help in investigating the CO<sub>2</sub> insertion reactions under batch conditions

**Keywords:** CO<sub>2</sub> insertion • cyclic organic carbonates • terminal epoxides • diethylene glycol • alkali metal salts

- [1] M. Aresta, Ed. , *Carbon Dioxide as Chemical Feedstock*, Wiley-VCH, Weinheim, **2010**.
- [2] J. Artz, T. E. Müller, K. Thenert, J. Kleinekorte, R. Meys, A. Sternberg, A. Bardow, W. Leitner, *Chem. Rev.* **2018**, *118*, 434–504.
- [3] Q. Liu, L. Wu, R. Jackstell, M. Beller, *Nat. Commun.* **2015**, *6*, 5933.
- [4] C. Martín, G. Fiorani, A. W. Kleij, *ACS Catal.* **2015**, *5*, 1353–1370.
- [5] A. J. Kamphuis, F. Picchioni, P. P. Pescarmona, *Green Chem.* **2019**, *21*, 406–448.
- [6] M. Alves, B. Grignard, R. Mereau, C. Jerome, T. Tassaing, C. Detrembleur, *Catal. Sci. Technol.* **2017**, *7*, 2651–2684.
- [7] J. W. Comerford, I. D. V. Ingram, M. North, X. Wu, *Green Chem.* **2015**, *17*, 1966–1987.
- [8] C. J. Whiteoak, N. Kielland, V. Laserna, E. C. Escudero-Adán, E. Martin, A. W. Kleij, *J. Am. Chem. Soc.* **2013**, *135*, 1228–1231.
- [9] V. Laserna, G. Fiorani, C. J. Whiteoak, E. Martin, E. Escudero-Adán, A. W. Kleij, *Angew. Chem. Int. Ed.* **2014**, *53*, 10416–10419.
- [10] G. Fiorani, M. Stuck, C. Martín, M. M. Belmonte, E. Martin, E. C. Escudero-Adán, A. W. Kleij, *ChemSusChem* **2016**, *9*, 1304–1311.
- [11] J. Martínez, F. de la Cruz-Martínez, M. A. Gaona, E. Pinilla-Peñalver, J. Fernández-Baeza, A. M. Rodríguez, J. A. Castro-Osma, A. Otero, A. Lara-Sánchez, *Inorg. Chem.* **2019**, *58*, 3396–3408.
- [12] H. Seo, L. V. Nguyen, T. F. Jamison, *Adv. Synth. Catal.* **2019**, *361*, 247–264.
- [13] X.-B. Lu, J.-H. Xiu, R. He, K. Jin, L.-M. Luo, X.-J. Feng, *Appl. Catal. A: Gen.* **2004**, *275*, 73–78.
- [14] L. Guo, L. Deng, X. Jin, Y. Wang, H. Wang, *RSC Adv.* **2018**, *8*, 26554–26562.
- [15] M. North, P. Villuendas, C. Young, *Chem. Eur. J.* **2009**, *15*, 11454–11457.
- [16] A. Rehman, A. M. López Fernández, M. F. M. G. Resul, A. Harvey, *J. CO2 Util.* **2018**, *24*, 341–349.
- [17] X. Wu, M. Wang, Y. Xie, C. Chen, K. Li, M. Yuan, X. Zhao, Z. Hou, *Appl. Catal. A: Gen.* **2016**, *519*, 146–154.
- [18] B. R. James, J. A. Boissonault, A. G. Wong-Foy, A. J. Matzger, M. S. Sanford, *RSC Adv.* **2018**, *8*, 2132–2137.
- [19] H. Yasuda, L. He, T. Takahashi, T. Sakakura, *Appl. Catal. A: Gen.* **2006**, *298*, 177–180.
- [20] V. H. Jadhav, S. H. Jang, H.-J. Jeong, S. T. Lim, M.-H. Sohn, J.-Y. Kim, S. Lee, J. W. Lee, C. E. Song, D. W. Kim, *Chem. Eur. J.* **2012**, *18*, 3918–3924.
- [21] G. Rokicki, W. Kuran, B. Pogorzelska-Marciniak, *Monatsh. Chem.* **1984**, *115*, 205–214.
- [22] J. Tharun, G. Mathai, A. C. Kathalikkattil, R. Roshan, J.-Y. Kwak, D.-W. Park, *Green Chem.* **2013**, *15*, 1673–1677.
- [23] S. Kaneko, S. Shirakawa, *ACS Sustainable Chem. Eng.* **2017**, *5*, 2836–2840.
- [24] S. Kumar, S. L. Jain, *Ind. Eng. Chem. Res.* **2014**, *53*, 541–546.
- [25] J. Steinbauer, T. Werner, *ChemSusChem* **2017**, *10*, 3025–3029.
- [26] J. Steinbauer, A. Spannenberg, T. Werner, *Green Chem.* **2017**, *19*, 3769–3779.
- [27] Y. Hu, J. Steinbauer, V. Stefanow, A. Spannenberg, T. Werner, *ACS Sustainable Chem. Eng.* **2019**, *7*, 13257–13269.
- [28] V. Butera, H. Detz, *ACS Omega* **2020**, *5*, 18064–18072.
- [29] C. C. Truong, D. K. Mishra, *J. CO2 Util.* **2020**, *41*, 101252.
- [30] S. Guidi, M. Noè, P. Riello, A. Perosa, M. Selva, *Molecules* **2016**, *21*, 657.
- [31] L. Cattelan, A. Perosa, P. Riello, T. Maschmeyer, M. Selva, *ChemSusChem* **2017**, *10*, 1571–1583.
- [32] R. Calmanti, M. Galvan, E. Amadio, A. Perosa, M. Selva, *ACS Sustainable Chem. Eng.* **2018**, *6*, 3964–3973.
- [33] L. Cattelan, G. Fiorani, A. Perosa, T. Maschmeyer, M. Selva, *ACS Sustainable Chem. Eng.* **2018**, *6*, 9488–9497.
- [34] M. Liu, X. Wang, Y. Jiang, J. Sun and M. Arai, *Catal. Rev.*, **2018**, *61*, 214–269
- [35] N. Tenhumberg, H. Büttner, B. Schäffner, D. Kruse, M. Blumenstein and T. Werner, *Green Chem.*, **2016**, *18*, 3775–3788.
- [36] M. B. Plutschack, B. Pieber, K. Gilmore, P. H. Seeberger, *Chem. Rev.* **2017**, *117*, 11796–11893.
- [37] F. Gomollón-Bel, *Chem. Int.* **2019**, *41*, 12–17.

- [38] D. Rigo, G. Fiorani, A. Perosa, M. Selva, *ACS Sustainable Chem. Eng.* **2019**, *7*, 18810–18818.
- [39] <https://www.meglobal.biz/products/diethylene-glycol/physicalproperties/> (last access dec. 2020)
- [40] C. J. Whiteoak, A. H. Henseler, C. Ayats, A. W. Kleij, M. Pericas *Green Chem.*, **2014**, *16*, 1552–1559.
- [41] M. Brivio, W. Verboom, D. N. Reinhoudt, *Lab Chip* **2006**, *6*, 329.
- [42] T. Andersson, P. Pucar, *J. Process Control* **1995**, *5*, 9–17.
- [43] S. Lohse, B. T. Kohnen, D. Janasek, P. S. Dittrich, J. Franzke, D. W. Agar, *Lab Chip* **2008**, *8*, 431.
- [44] A. Sainz Martinez, C. Hauzenberger, A. R. Sahoo, Z. Csendes, H. Hoffmann, K. Bica, *ACS Sustainable Chem. Eng.* **2018**, *6*, 13131–13139.
- [45] T. Q. Bui, L. J. Konwar, A. Samikannu, D. Nikjoo, J.-P. Mikkola, *ACS Sustainable Chem. Eng.* **2020**, *8*, 12852–12869.
- [46] R. T. L. Ng, D. H. S. Tay, D. K. S. Ng, *Energy Fuels* **2012**, *26*, 7316–7330.
- [47] K. Kawabe *Catal Surv Asia* **2010**, *14*, 111–115

## Entry for the Table of Contents

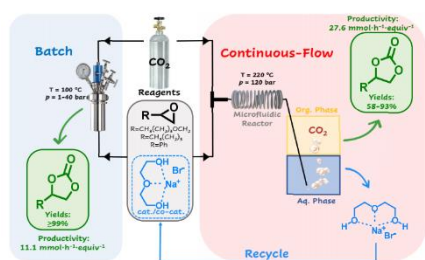

CO<sub>2</sub> insertion on terminal epoxides was performed under batch conditions and in continuous flow using an inexpensive and sustainable binary homogeneous mixture comprised of NaBr as the catalyst and diethylene glycol (DEG) as both solvent and catalyst activator. At complete conversion, cyclic carbonate products were obtained in up to 99% selectivity from styrene oxide, 1,2-epoxyhexane and butyl glycidyl ether.